



ENVASES SANZ BELDA, S.L.

Tel.: 34 96 236 02 32 - calidad@envasesanzbelda.es - www.envasesanzbelda.es
Pol. Ind. San José. Avda, Valencia, parc. 7 - Apdo. de Correos 46 - 46812 Aielo de Malferit, Valencia. (España)



Technical comercial data

N-5.8 T.N.T-5.8

Serie NOVA – Versión 31-07-2024

TECHNICAL DATA:

Material:	PP copolymer of first quality, suitable for contact with food according to current regulations.
Colours:	White standard. Consult for other colours.
Useful Volume:	5.8 litres
Volume to the edge:	6.3 litres
Weight of the bucket:	202 g. approx.
Weight of the lid:	53 g. approx.
Weight of the handle (plastic):	8 g. approx.
Total Weight:	263 g. approx.
Decorative surface flat inks:	155 x 595 mm (height x perimeter)
Design surface photographic finish:	165 x 605 mm (height x perimeter)



MEASUREMENTS:

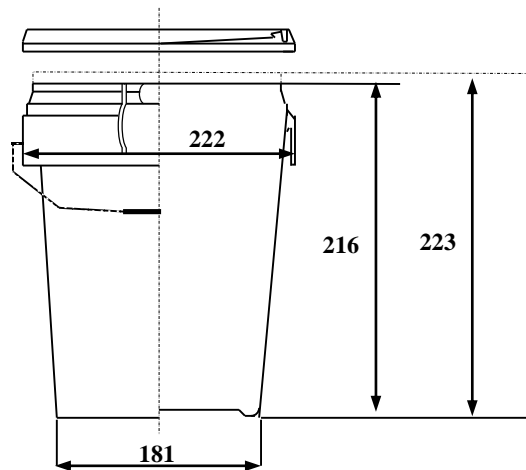

Measurements in millimetres

GROUPING OF TRANSPORT:

Buckets:	600 buckets per pallet
Pallet dimensions:	1180 x 950 x 1140 (see drawing)
Lids:	200 lids per box, this serves as a packaging of transportation
Box dimension:	444 x 228 x 745

